

Deutsches Institut für Bautechnik

Anstalt des öffentlichen Rechts

Kolonnenstr. 30 L
10829 Berlin
Germany

Tel.: +49(0)30 787 30 0
Fax: +49(0)30 787 30 320
E-mail: dibt@dibt.de
Internet: www.dibt.de



DIBt

Mitglied der EOTA
Member of EOTA

European Technical Approval ETA-10/0241

English translation prepared by DIBt - Original version in German language

Handelsbezeichnung
Trade name

LenoTec

LenoTec

Zulassungsinhaber
Holder of approval

Finnforest Merk GmbH
Industriestraße 2
86551 Aichach

Zulassungsgegenstand
und Verwendungszweck
*Generic type and use
of construction product*

Massive plattenförmige Holzbauelemente zur Verwendung als tragende Teile in Bauwerken
Solid wood slab elements to be used as structural elements in buildings

Geltungsdauer: vom
Validity: from
bis
to

12 August 2010

12 August 2015

Herstellwerk
Manufacturing plant

Finnforest Merk GmbH
Industriestraße 2
86551 Aichach
DEUTSCHLAND

Diese Zulassung umfasst
This Approval contains

19 Seiten einschließlich 5 Anhänge
19 pages including 5 annexes



Europäische Organisation für Technische Zulassungen
European Organisation for Technical Approvals

I LEGAL BASES AND GENERAL CONDITIONS

- 1 This European technical approval is issued by Deutsches Institut für Bautechnik in accordance with:
 - Council Directive 89/106/EEC of 21 December 1988 on the approximation of laws, regulations and administrative provisions of Member States relating to construction products¹, modified by Council Directive 93/68/EEC² and Regulation (EC) N° 1882/2003 of the European Parliament and of the Council³;
 - Gesetz über das In-Verkehr-Bringen von und den freien Warenverkehr mit Bauprodukten zur Umsetzung der Richtlinie 89/106/EWG des Rates vom 21. Dezember 1988 zur Angleichung der Rechts- und Verwaltungsvorschriften der Mitgliedstaaten über Bauprodukte und anderer Rechtsakte der Europäischen Gemeinschaften (Bauproduktengesetz - BauPG) vom 28. April 1998⁴, as amended by law of 31 October 2006⁵;
 - Common Procedural Rules for Requesting, Preparing and the Granting of European technical approvals set out in the Annex to Commission Decision 94/23/EC⁶.
- 2 Deutsches Institut für Bautechnik is authorized to check whether the provisions of this European technical approval are met. Checking may take place in the manufacturing plant. Nevertheless, the responsibility for the conformity of the products to the European technical approval and for their fitness for the intended use remains with the holder of the European technical approval.
- 3 This European technical approval is not to be transferred to manufacturers or agents of manufacturers other than those indicated on page 1, or manufacturing plants other than those indicated on page 1 of this European technical approval.
- 4 This European technical approval may be withdrawn by Deutsches Institut für Bautechnik, in particular pursuant to information by the Commission according to Article 5(1) of Council Directive 89/106/EEC.
- 5 Reproduction of this European technical approval including transmission by electronic means shall be in full. However, partial reproduction can be made with the written consent of Deutsches Institut für Bautechnik. In this case partial reproduction has to be designated as such. Texts and drawings of advertising brochures shall not contradict or misuse the European technical approval.
- 6 The European technical approval is issued by the approval body in its official language. This version corresponds fully to the version circulated within EOTA. Translations into other languages have to be designated as such.

1 Official Journal of the European Communities L 40, 11 February 1989, p. 12
2 Official Journal of the European Communities L 220, 30 August 1993, p. 1
3 Official Journal of the European Union L 284, 31 October 2003, p. 25
4 *Bundesgesetzblatt Teil I 1998*, p. 812
5 *Bundesgesetzblatt Teil I 2006*, p.2407, 2416
6 Official Journal of the European Communities L 17, 20 January 1994, p. 34

II SPECIFIC CONDITIONS OF THE EUROPEAN TECHNICAL APPROVAL

1 Definition of product and intended use

1.1 Definition of the construction product

LenoTec are plane solid wood slab elements made of at least 3 crosswise glued softwood boards. Adjacent layers of the softwood boards are arranged perpendicular (angle of 90°) to each other. The cross-section of the solid wood slabs shall be symmetrically or nearly symmetrically.

The principle structure of the solid wood slab is shown in annex 1. Details, about which configurations are allowed, are given in chapter 2.1.2.

A maximum of three adjacent layers may be arranged in the same direction as long as a nearly symmetric cross-section with cross layering remains.

Surfaces are planed. They can be slightly bent as long as the bending does not influence the characteristics of the elements as described in this European technical approval.

The surface layers of the elements may be replaced by solid wood panels or structural laminated veneer lumber panels. For elements with three layers the middle layer may be replaced by a layer of structural laminated veneer lumber.

The products may be covered with gypsum boards or gypsum fibreboards on one or both sides. These panels may not be used for calculation of the elements.

The application of chemical substances (wood preservatives and flame-protective agents) is not subject of this European Technical Approval.

1.2 Intended use

The solid wood slabs are intended to be used as a load-bearing, bracing or non structural element in buildings and timber structures. It shall be subjected to static and quasi static actions only.

The solid wood slab is intended to be used in service classes 1 and 2 according to EN 1995-1-1.

The provisions made in this European technical approval are based on an assumed working life of the solid wood slabs of 50 years, provided that the conditions laid down in section(s) 4.2 and 5 for the packaging, transport, storage, installation, use, maintenance, repair are met. The indications given on the working life cannot be interpreted as a guarantee given by the producer, but are to be regarded only as a means for choosing the right products in relation to the expected economically reasonable working life of the works.

2 Characteristics of product and methods of verification

2.1 Characteristics of the product and its components

2.1.1 General

The solid wood slab elements and their components correspond to the information given in the annexes 1 to 3 of this European Technical Approval. Details on the elements are deposited with Deutsches Institut für Bautechnik (DIBt).

2.1.2 Construction of the solid wood slab

A specification of the composition of the solid wood slabs and of the boards to be used is given in the annexes 1 and 2.

Boards are visually or machine strength graded. Only technically dried wood shall be used.

Only boards, which are planed on both sides shall be used. The boards shall be connected by finger joints according to EN 385⁷ in longitudinal direction. Butt joints are not permissible.

⁷ EN 385:2001 Finger jointed structural timber - Performance requirements and minimum production requirements

The elements can be connected by universal finger joints according to EN 387⁸.

The boards can be grooved with notches of approx. 2,5 mm width in intervals of 40 to 80 mm. For elements of three layers notches with a width of 20 mm or 40 mm according to annex 2 are allowed. The distance between the notches and between notch and edge must be between 40 mm and 80 mm. The remaining thickness of the board in field of the notches must be between 4 mm and 7 mm.

The boards within a layer are not glued together on their adjacent surfaces. The acceptable width of gaps is given in annex 2.

If structural laminated veneer lumber is used as surface layer or, for elements with three layers, as middle layer, it must fulfil the requirements as stated in EN 14374⁹ and as deposited with Deutsches Institut für Bautechnik.

If solid wood panels are used, they must fulfil the requirements as stated in EN 13986¹⁰ or in a European technical approval.

The structural laminated veneer lumber and the solid wood panels shall have a maximum thickness of 33 mm.

If gypsum boards or gypsum fibre boards are used as additional layer, they must fulfil the requirements as stated in EN 520¹¹, EN 15283-2¹² or a European technical approval. The gypsum boards or gypsum fibre boards might not be taken into account for calculation.

The laminated veneer lumber, the solid wood panels, the gypsum plaster boards and gypsum fibre boards are only components of the product "LenoTec". They are not regulated independently in this European technical approval. National regulations might have to be followed for their use.

The cross section shall be symmetric. In case of deviances from the symmetry the distance between the stresses neutral line and the geometrical middle of the cross section shall not be more than 1/10 of the thickness of the element.

The elements might be bent depending on the thickness of the layers as follows:

Thickness of the layer ≤ 12 mm	bending radius $R \geq 250 \cdot d$,
Thickness of the layer > 12 bis ≤ 17 mm	bending radius $R \geq 350 \cdot d$,
Thickness of the layer > 17 bis ≤ 22 mm	bending radius $R \geq 420 \cdot d$,
Thickness of the layer > 22 bis ≤ 27 mm	bending radius $R \geq 500 \cdot d$,

with

R = bending radius of a single board

d = thickness of a single board of a bended layer.

8	EN 387:2001	Glued laminated timber - Large finger joints - Performance requirements and minimum production requirements
9	EN 14374:2004	Timber structures - Structural laminated veneer lumber - Requirements
10	EN 13986:2004	Wood-based panels for use in construction - Characteristics, evaluation of conformity and marking
11	EN 520:2004	Gipsplatten - Begriffe, Anforderungen und Prüfverfahren
12	EN 15283-2:2009	Gypsum boards with fibrous reinforcement – Definitions, requirements and test methods – Part 2: Gypsum fibre boards

2.1.3 Adhesive

The adhesive for gluing the layers, the finger joints of the individual boards and the universal finger joints shall be an adhesive "Type I" conform to EN 301¹³ which passed the tests according to EN 302-1 to EN 302-4¹⁴. Alternatively a PU – adhesive fulfilling the requirements of EN 14080¹⁵, Annex C, might be used. For the classification EN 15425¹⁶ applies.

This also applies for solid wood panels and laminated veneer lumber being part of the product.

The adhesive used must be conform to the information deposited with Deutsches Institut für Bautechnik.

2.2 Mechanical resistance and stability

The specifications regarding mechanical resistance and stability are given in annexes 2 to 5. Design can be carried out according to EN 1995-1-1.

2.3 Behaviour in case of fire

2.3.1 Reaction to fire

In accordance with Commission Decision 2003/43/EC the solid wood slab elements covered by this European technical approval for use as wall, roof, ceiling and special construction components comply with Euroclass D-s2,d0 according to EN 13501-1¹⁷. For the use as floor construction components they comply with Euroclass D_{FL}-s1. The boundary conditions stated in the commission decision have to be attended for this classification.

The Decision of the European Commission might not apply if additional layers are part of the element, depending on the additional layers used and the boundary conditions affected.

Note:

A European reference fire scenario for façades has not been laid down. In some Member States, the classification of the solid wood slabs according to EN 13501-1¹⁷ might not be sufficient for the use in façades. An additional assessment of the solid wood slabs according to national provisions (e.g. on the basis of a large scale test) might be necessary to comply with Member State regulations, until the existing European classification system has been completed.

2.3.2 Resistance to fire

The resistance to fire performance can be calculated according to EN 1995-1-2 using the charring rate given in annex 3. Occurring asymmetries have to be taken into account. The remaining cross section might not be thinner than 3 mm.

13	EN 301:2006	Adhesives, phenolic and aminoplastic, for load-bearing timber structures - Classification and performance requirements
14	EN 302-1 to -4	Adhesives for load-bearing timber structures - Test methods - Part 1: Determination of bond strength in longitudinal tensile shear strength; 2004 Part 2: Determination of resistance to delamination; 2004 Adhesives for load-bearing timber structures - Test methods - Part 3: Determination of the effect of acid damage to wood fibres by temperature and humidity cycling on the transverse tensile strength; 2004 + A1:2005 Adhesives for load-bearing timber structures - Test methods - Part 4: Determination of the effects of wood shrinkage on the shear strength; 2004
15	EN 14080:2005	Timber structures - Glued laminated timber - Requirements
16	EN 15425:2008	Adhesives - One component polyurethane for load bearing timber structures - Classification and performance requirements
17	EN 13501-1:2007	Fire classification of construction products and building elements - Classification using data from reaction to fire tests

2.4 Hygiene, health and the environment

A manufacturer's declaration has been submitted that no dangerous substances are used in the product regulated by this European technical approval.

Wood preservatives or flame retardants are not part of this European Technical Approval.

The class of release of formaldehyde has been determined according to EN 13986 with regard to solid wood panels.

The product Lenotec fulfils the classification E1 for assemblies with and without laminated veneer lumber. For assemblies with solid wood panels "no performance determined" applies.

Note:

In addition to the specific clauses relating to dangerous substances contained in this European technical approval, there may be other requirements applicable to the products falling within its scope (e.g. transposed European legislation and national laws, regulations and administrative provisions). In order to meet the provisions of the Construction Products Directive, these requirements need also to be complied with, when and where they apply.

2.5 Methods of verification

The assessment of the fitness of the solid wood slab for the intended use in relation to the requirements for mechanical resistance and stability, for safety in case of fire, for hygiene, health and the environment, for protection against noise, for energy economy and heat retention, as well as for durability in the sense of these Essential has been made in compliance with the assessment rules for solid wood slabs agreed upon within EOTA.

3 Evaluation and attestation of conformity and CE marking

3.1 System of attestation of conformity

According to the Decision 97/176/EC¹⁸ of the European Commission for the product family 2/3 system 1 of the attestation of conformity applies.

This system of attestation of conformity is defined as follows:

System 1: Certification of the conformity of the product by an approved certification body on the basis of:

(a) Tasks for the manufacturer:

- (1) factory production control;
- (2) further testing of samples taken at the factory by the manufacturer in accordance with a prescribed test plan;

(b) Tasks for the approved body:

- (3) initial type-testing of the product;
- (4) initial inspection of factory and of factory production control;
- (5) continuous surveillance, assessment and approval of factory production control.

Note: Approved bodies are also referred to as "notified bodies".

3.2 Responsibilities

3.2.1 Tasks for the manufacturer

3.2.1.1 Factory production control

The manufacturer shall exercise permanent internal control of production. All the elements, requirements and provisions adopted by the manufacturer shall be documented in a systematic manner in the form of written policies and procedures, including records of results performed. This production control system shall insure that the product is in conformity with this European technical approval.

The manufacturer may only use constituent materials stated in the technical documentation of this European technical approval.

The factory production control shall be in accordance with the "control plan of 12 August 2010 relating to the European technical approval ETA-10/0241" issued on 12 August 2010 which is part of the technical documentation of this European technical approval. The control plan is laid down in the context of the factory production control system operated by the manufacturer and deposited with Deutsches Institut für Bautechnik.¹⁹

The results of factory production control shall be recorded and evaluated in accordance with the provisions of the control plan. The records include at least:

- Designation of the product, basic materials and components;
- Type of control or testing;
- Date of manufacture of the product and date of testing of the product or basic materials or components;
- Results of control and testing and, if appropriate, comparison with requirements;
- Name and signature of person responsible for factory production control.

3.2.1.2 Other tasks for the manufacturer

The manufacturer shall, on the basis of a contract, involve a body which is approved for the tasks referred to in section 3.1 in order to undertake the actions laid down in section 3.2.2. For this purpose, the control plan referred to in sections 3.2.1.1 and 3.2.2 shall be handed over by the manufacturer to the approved body involved.

The manufacturer shall make a declaration of conformity, stating that the construction product is in conformity with the provisions of the European technical approval ETA-10/0241 issued on 12 August 2010. The declaration of conformity can only be given if the provisions of this ETA are met and the control plan is being followed.

3.2.2 Tasks for the approved bodies

The approved body shall perform the

- initial type-testing of the product,
- initial inspection of factory and of factory production control,
- continuous surveillance, assessment and approval of factory production

in accordance with the provisions laid down in the control plan.

The initial inspection of the factory shall include the inspection of the factory plant, the technical equipment and the qualification of the staff.

The approved body shall retain the essential points of its actions referred to above and state the results obtained and conclusions drawn in a written report.

The approved certification body involved by the manufacturer shall issue an EC certificate of conformity of the product stating the conformity with the provisions of this European technical approval. The certificate of conformity can only be given if the provisions of this ETA are met and the control plan is being followed.

In cases where the provisions of the European technical approval and its control plan are no longer fulfilled the certification body shall withdraw the certificate of conformity and inform Deutsches Institut für Bautechnik without delay.

¹⁹ The "control plan" is a confidential part of the European technical approval and only handed over to the approved body involved in the procedure of attestation of conformity. See section 3.2.2.

3.3 CE marking

The CE marking shall be affixed on the product itself, a label attached to it, the packaging or the accompanying commercial document.

The letters "CE" shall be followed by the identification number of the approved certification body and shall be accompanied by the following additional information:

- the name and address of the producer (legal entity responsible for the manufacture),
- the last two digits of the year in which the CE marking was affixed,
- the number of the EC certificate of conformity for the product,
- the number of the European technical approval,
- description of the element, showing its intended use,
- species of the wood used,
- number and arrangement of the layers,
- nominal thickness of the element,
- strength class of the wood of each layer
- class of release of formaldehyde (if required)
- type and classification of the adhesive used

For the CE – marking of laminated veneer lumber (LVL), Solid wood panels (SWP), gypsum boards and gypsum fibre boards used within the element the regulations provided in the associated European standards or European Technical Approvals apply. The characteristics of this product parts shall be included in the CE – marking of the product "LenoTec" according to this European Technical Approval.

4 Assumptions under which the fitness of the products for the intended use was favourably assessed

4.1 Manufacturing

The solid wood slabs are manufactured in accordance with the provisions of this European Technical Approval using the automated manufacturing process as identified in the inspection of the plant by the Deutsches Institut für Bautechnik and laid down in the technical documentation.

The layers shall be glued together to the required thickness of the solid wood slabs.

The adhesive deposited with Deutsches Institut für Bautechnik shall be used for manufacturing. This applies also to laminated veneer lumber planes if they are part of the element.

For elements with three layers and a middle layer of laminated veneer lumber it shall be observed that the boards are arranged vertically and the direction of the grain of the surface layers is arranged horizontally.

The European technical approval is issued for the product on the basis of agreed data/information, deposited with Deutsches Institut für Bautechnik, which identifies the product that has been assessed and judged. Changes to the product or production process, which could result in this deposited data/information being incorrect, should be notified to Deutsches Institut für Bautechnik before the changes are introduced. Deutsches Institut für Bautechnik will decide whether or not such changes affect the approval and consequently the validity of the CE marking on the basis of the approval and if so whether further assessment or alterations to the approval shall be necessary.

4.2 Installation

4.2.1 Design of solid wood slab elements

The European Technical Approval only applies to the manufacture and use of the solid wood slab. Verification of stability of the works including application of loads on the solid wood slab is not subject of this European Technical Approval.

Fitness for the intended use of the solid wood slab is given under the following conditions:

- Design of the solid wood slab elements is carried under the responsibility of an engineer experienced in solid wood slab elements.
- Design of the works shall account for the protection of the solid wood slab elements.
- The solid wood slab elements are installed correctly.

Design of the solid wood slab elements may be undertaken according to EN 1995-1-1 taking into account the annexes of this European Technical Approval. Standards and regulations valid in the place of use shall be considered.

4.2.2 Installation of solid wood slab elements

The manufacturer shall prepare installation instructions in which the product-specific characteristics and important measures to be taken into consideration for installation are described. The installation instructions shall be available at every construction site.

Solid wood slab element installation shall be carried out by appropriately qualified personnel under the supervision of the person responsible for technical matters on site.

The elements shall be provided with an effective protection against weather in service.

5 Indications to the manufacturer

5.1 General

The manufacturer shall ensure that the requirements in accordance with the clauses 1, 2 and 4 as well as with the Annexes of this European Technical Approval are made known to those who are concerned during planning and execution of the works.

5.2 Recommendations on packaging, transport and storage

The solid wood slab elements shall be protected during transport and storage against any damage and detrimental moisture effects. The manufacturer's instruction for packaging, transport and storage shall be observed.

5.3 Use, maintenance, repair

The assessment of the fitness for use is based on the assumption that maintenance is not required during the assumed intended working life. In case of a severe damage of a solid wood slab element immediate actions regarding the mechanical resistance and stability of the works shall be initiated. Should this situation arise replacement of the elements can be necessary.

Dipl.-Ing. Georg Feistel
Abteilungsleiter
Berlin, 12. August 2010

beglaubigt:
Warns

Annex 1	Construction of the wood slab elements
----------------	---

Construction of the wood slab elements "LenoTec" (example)

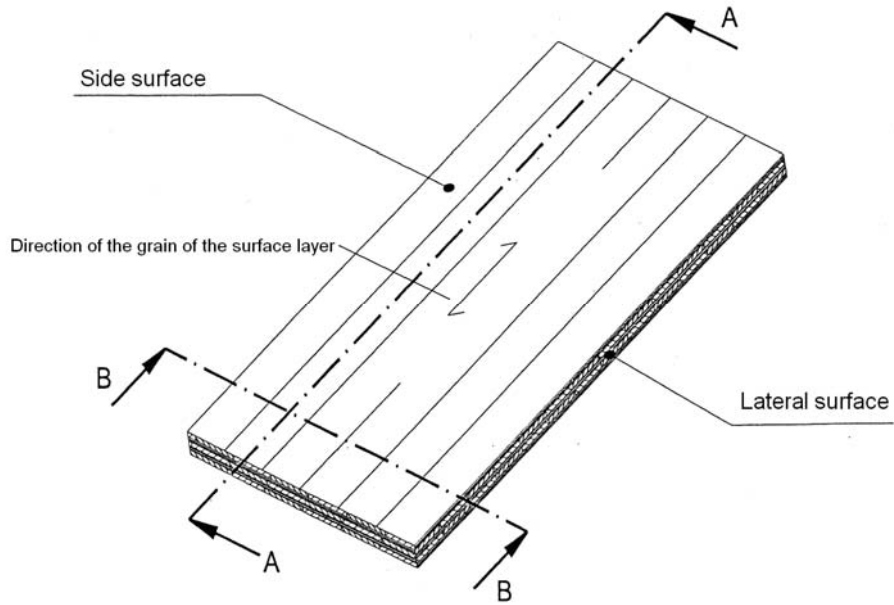

sectional drawing A - A
 (5 layer element)

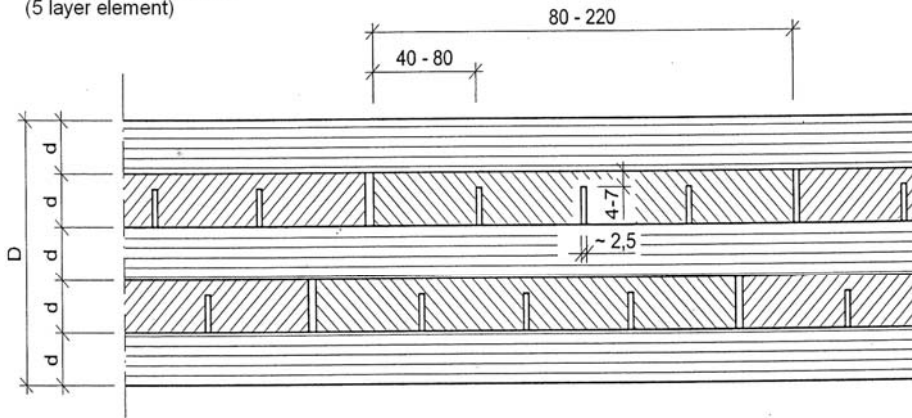

sectional drawing B - B:

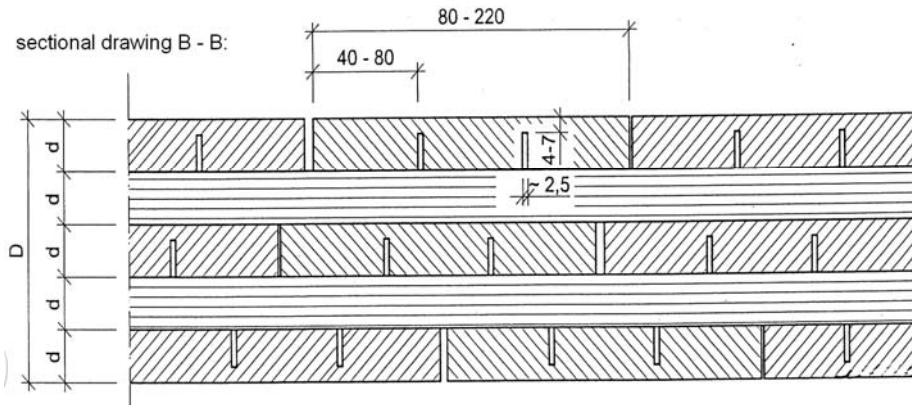

d = thickness of board (10 mm ≤ d ≤ 33 mm)
 D = thickness of the element

Annex 1	Construction of the wood slab elements
----------------	---

Assembly of the three layer elements with notches

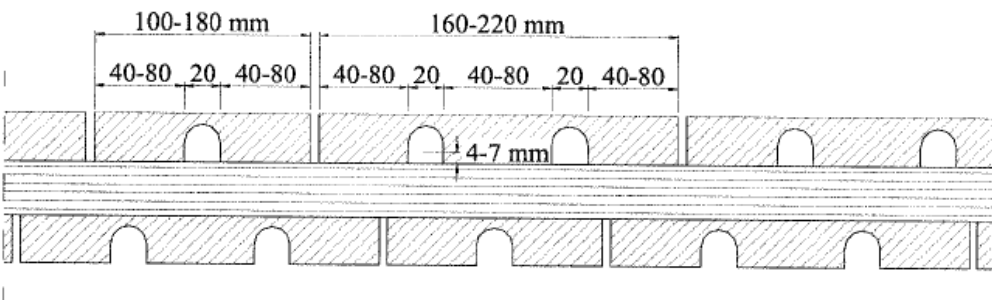
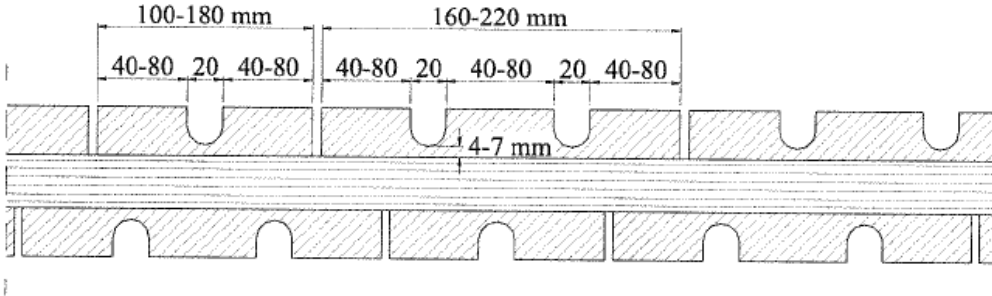
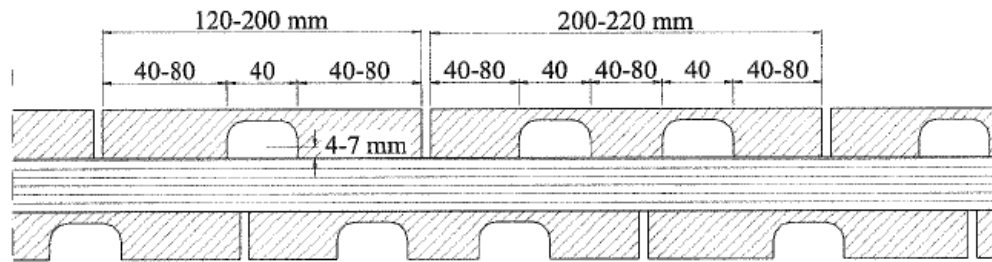
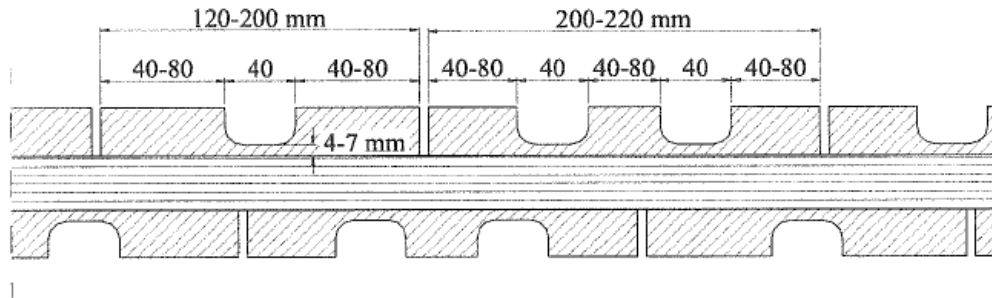

Annex 2	Dimensions and specifications of the solid wood slabs
----------------	--

Table 1: Dimensions and specifications of the elements

Characteristic	Specification
Elements	
Thickness	30 bis 300 mm
Width	≤ 4,8 m
Length	≤ 30 m
Number of layers	≥ 3
Number of consecutive layers having the same direction	≤ 3
Maximum width of gaps between the boards	6 mm
Boards	
Material	softwood
Strength class according to EN 338 ²⁰	≥ C16*
Thickness	10 bis 33 mm
Width	80 bis 220 mm
Ratio width to thickness of the cross-layers	≥ 4:1
Moisture of wood according to EN 13183-2 ²¹	12 ± 2 %
<p>* Within each layer a maximum of 10% of the boards may belong to a lower strength class without being considered. The following combinations are possible: 100 % C 16; 90 % C24 / 10 % C16; 90 % C30 / 10 % C24; 90 % C35 / 10 % C30 und 90 % C40 / 10 % C35.</p>	

²⁰ EN 338:2009 Timber structures - Strength classes

²¹ EN 13183-2:2002 Moisture content of a piece of sawn timber - Part 2: Estimation by electrical resistance method

Annex 3	Essential requirements of the solid wood slabs
----------------	---

Table 2: Essential Requirements of the solid wood slabs

ER	Requirement	Verification method	Class / Use category / value	
Mechanical resistance and stability				
1	Mechanical actions in plane of the solid wood slab	For the calculation the characteristic strength and stiffness values of softwood according to EN 338 ²⁰ shall be used taking into consideration the definitions in annex 2. In addition the following values apply:		
		Characteristic	Thickness of element	
			≤ 115 mm	> 115 mm
	Mechanical actions perpendicular to the solid wood slab	Rolling shear strength (5% - fractile)	$f_{R,k}$	0,85 N/m ² 0,70 N/mm ²
		Rolling shear modulus (mean value)	$G_{R,mean}$	50 N/mm ² 50 N/mm ²
		If elements are connected by universal finger joints according to EN 387 ⁸ , the characteristic values for bending, tension and compression shall be reduced by 40% in field of the universal finger joint. For the characteristic values of solid wood panels and structural laminated veneer lumber the rules of the associated European standard or European technical approval apply. National regulations might have to be followed. For references regarding the calculation see annexes 4 and 5		
	Use of fasteners	According to EN 1995-1-1, for further details see annex 4		
	Creep and duration of load	According to EN 1995-1-1		
	Dimensional stability	Moisture content during use shall not change to such extent that adverse deformations can occur.		
Behaviour in case of fire				
Reaction to fire				
2	Solid wood panels except for floorings	Commission Decision 2003/43/EC	Euroclass D-s2,d0	
	Floorings		Euroclass D _{fl} -s1	
Resistance to fire				
	Charring rate	EN 1995-1-2	0,7 mm/min	
Hygiene, health and the environment				
3	Vapour permeability μ	EN 12524 ²²	20 to 50	
	Release of formaldehyde	En 13986 with regard to solid wood panels	Klasse E1*	
Safety in use				
4	Slipperiness		No performance determined	
	Impact resistance		No performance determined	

Annex 3	Essential requirements of the solid wood slabs
----------------	---

Table 2 (continued)

5	Protection against noise		
	Airbourne sound insulation		No performance determined
	Impact sound insulation		No performance determined
	Sound absorption		No performance determined
6	Energy economy and heat retention		
	Thermal conductivity λ	EN 12524 ²²	0,13 W/(m ² ·K)
	Air tightness		No performance determined
	Thermal inertia c_p	EN 12524 ²²	1.600 J/(kg·K)
-	Durability		
	Use only in service classes	EN 1995-1-1	1 und 2
* For assemblies with solid wood panels "no performance determined" applies.			

Annex 4	Recommendations for the design of the elements and the fasteners
----------------	---

Recommendations for design and calculation of the elements and fasteners

1 Recommendations for design of the elements

1.1 General

Design, calculation and realization can be done according to EN 1995-1-1 taking into account the following provisions. For the calculation according to EN 1995-1-1 national regulations may have to be followed.

The determination of the distribution of stresses and internal forces must consider the influence of shear deformations. In annex 5 advice is given on how to perform the calculation of the elements.

If using panels as cover, the deformation of the covers might have to be taken into account. These cover layers may not be used for calculation of the elements.

For the calculations regarding rolling shear, bending stresses and buckling of elements with three layers and large notches (see Annex 1, page 11) the remaining cross-section can be considered with:

for notches of 20 mm B · 0,75

for notches of 40 mm B · 0,60

with

B = width of a board without notches

1.2 Characteristic values

The characteristic strength and stiffness values can be taken from the annexes 2 and 3. In addition the following applies:

While calculating the part of the deformation due to shear forces, the element's thickness D regardless of the configuration and a shear modulus of $G = 60 \text{ N/mm}^2$ may be used.

1.3 Mechanical actions perpendicular to element plane

1.3.1 Bending and shear

For the calculation of the characteristic values of the element according to annex 5, only the boards, which are oriented parallel to the direction of load, might be considered.

For the calculation of the bending stresses for the boards within one layer the design value of the bending strength might be multiplied with a system factor k_ℓ :

$$k_\ell = \min \begin{cases} 1 + 0,025 \cdot n \\ 1,1 \end{cases}$$

with n = number of boards lying side by side.

1.3.2 Tension and compression

The behaviour in bearing and deformation against compression perpendicular to the element's plane can be calculated according to EN 1995-1-1 using the strength and stiffness values given in chapter 1.2.

Tension loads perpendicular tot the element should be avoided.

Annex 4	Recommendations for the design of the elements and the fasteners
----------------	---

1.4 Mechanical actions in plane of the element

For loads in plane of the element only layers can be taken into account, where the direction of the grain is parallel to the stresses occurring from external loads.

1.4.1 Shear

If forces between adjacent boards of a layer are transmitted only by means of using the next layer glued crosswise, the shear stresses in the crossing surfaces have to be calculated as follows:

$$\tau_{T,d} = \frac{F_d \cdot h}{\sum I_p} \cdot \frac{a}{2} \leq f_{v,d}$$

with

F_d = external load of the element (N)

h = height of the wall (mm)

a = largest side length of the crossing area (mm)

I_p = polar moment of inertia of a certain crossing area i (mm⁴)

$\sum I_p$ = sum of all polar moments of inertia of the crossing areas in the element

$f_{v,d}$ = design value of the torsional shear strength; the characteristic value shall be set to $f_{v,k} = 2,5$ N/mm² for this calculation

$\tau_{T,d}$ = design value of the torsional stresses occurring as boards of one layer are regarded as not glued on their lateral sides for calculation purposes.

In addition it has to be verified that the layers can bear the stresses falling upon them.

1.4.2 Tension and compression

The behaviour in bearing- and deformation in the element's plane can be calculated according to EN 1995-1-1 using the strength and stiffness values given in chapter 1.2.

1.5 Buckling

For the calculation of buckling the instability factor for glued laminated timber might be taken into account. The calculation shall be performed with the geometry of the cross section as is.

2 Recommendations for the design of the fasteners

2.1 General

The characteristic values of the load bearing capacity of fasteners in the element shall be carried out according to EN 1995-1-1 or a European Technical Approval which has been granted for the relevant fastener as for softwood or for glued laminated timber. For the European regulations national provisions may apply.

Side surfaces are the surfaces of the element parallel to the plane of the element.

Lateral surfaces are the surfaces perpendicular to the plane of the element, consisting of the lateral surfaces and the cross grain of the boards.

As fasteners nails, wood screws, bolts and dowels, split ring and toothed-plate connectors according to EN 1995-1-1 or a European technical approval may be used.

Fasteners in the lateral surfaces of wood based panels used as cover layers are not allowed.

2.2 Bolts and dowels

The characteristic value of junctions with bolts and dowels in the side surfaces can be calculated according to EN 1995-1-1. Decisive for the embedment strength is the direction of the grain of the surface layer.

Bolts and dowels in the lateral surfaces might not be taken into consideration as load-bearing. Loads while mounting have to be considered separately.

The minimum distance and spacing for bolts and dowels must be 5·d from the loaded edge and between each other and 3·d from the unloaded edge. This applies regardless of the angle between the direction of force and the direction of the grain.

2.3 Nails

The characteristic value of the load-bearing capacity of nails in the side surfaces with loads perpendicular to their axis can be calculated according to EN 1995-1-1.

Decisive for the minimum spacing of the nails is the direction of the grain of the side surfaces.

Nails in the lateral surfaces might not be taken into consideration as load-bearing.

The diameter of nails must be at least 4 mm. Only grooved nails with a characteristic value of the point side withdrawal strength $f_{ax,k} \geq 50 \cdot 10^{-6} \cdot \rho_k^2$ and a characteristic value of the head side pull-through strength $f_{head,k} \geq 100 \cdot 10^{-6} \cdot \rho_k^2$ might be employed for axial loading (ρ_k = characteristic density in kg/m³; max. 500).

The characteristic axial withdrawal strength $f_{ax,k}$ of these nails can be taken into account as $f_{ax,k} = 40 \cdot 10^{-6} \cdot \rho_k^2$.

2.4 Screws

The characteristic value of the loadbearing capacity of screws in the side surfaces of the board can be calculated according to EN 1995-1-1.

Decisive for the minimum spacing of the screws is the direction of the grain of the side surfaces.

For axially loaded screws in the cross grain of lateral surfaces the parameter $f_{ax,k}$ has to be decreased by 25 %.

For the calculation according to EN 1995-1-1 the characteristic value of the loadbearing capacity can be calculated as for fasteners in single shear. As decisive diameter the outer diameter of the screw thread has to be used.

For the calculation of the bearing capacity of laterally loaded screws in longitudinal direction of the element in the lateral surfaces applies:

As characteristic value of the embedding strength of the wood on the side of the screw head the value of plywood might be taken into account.

As characteristic value of the embedding strength on the side of the cone point of the screw 50% of the value of softwood might be taken into account due to the possibility of hitting cross grain. For screws in the side surfaces or the longitudinal grain of the lateral surfaces the value of softwood might be taken into account.

As decisive diameter the outer diameter of the screw thread has to be used.

Screws in the lateral surfaces (cross grain or parallel to the grain) have to be perpendicular to the surface. In case it can not be excluded that the screw will hit cross grain, calculation shall be done with the values for cross grain.

Laterally loaded screws in the lateral surfaces with a load cross to the longitudinal direction of the elements are not allowed.

Laterally loaded screws in the side surfaces must have a diameter of at least 4 mm, in the lateral surfaces it must be at least 8 mm.

Annex 4	Recommendations for the design of the elements and the fasteners
----------------	---

For wood screws with a diameter of $d \leq 8$ mm pre-drilling is not required. If a pre-drilling is required, it has to be done with $0,7 \cdot d$ in the lateral surfaces.

For predrilled wood screw connections in the side surfaces the following minimum edge distances apply:

Load parallel to the grain of the surface layer 7d

Load perpendicular to the grain of the surface layer 4d

(d = outer diameter of the screw thread)

For screws with $d \leq 12$ mm an edge distance of ≥ 42 mm applies.

2.5 Split ring connectors and toothed-plate connectors

The characteristic value of the load-bearing capacity of split ring connectors and toothed-plate connectors in the side surfaces of the board can be calculated according to EN 1995-1-1.

For split ring connectors in the lateral surfaces the regulations for connections with split ring connectors in cross grain apply.

Toothed-plate connectors in the lateral surfaces might not be taken into consideration as load-bearing.

Annex 5	Design according to the theory of flexible bonded beams
----------------	--

Design according to the theory of flexible bonded beams

The calculation of elements with up to five layers can be performed using the theory of flexible bonded beams as described in EN 1995-1-1.

To consider deformations due to shear the factor s_i/K_i according to the standard is substituted by the factor $\bar{h}_i/(G_R \cdot b)$.

The effective moment of inertia is calculated by:

$$I_{ef} = \sum_{i=1}^3 (I_i \cdot \gamma_i \cdot A_i \cdot a_i^2) \quad \text{with} \quad A_i = b_i \cdot h_i; \quad I_i = \frac{b_i \cdot h_i^3}{12}$$

$$\gamma_1 = \frac{1}{1 + \frac{\pi^2 \cdot E_0 \cdot A_1 \cdot \bar{h}_1}{G_R \cdot b \cdot l^2}}; \quad \gamma_2 = 1; \quad \gamma_3 = \frac{1}{1 + \frac{\pi^2 \cdot E_0 \cdot A_3 \cdot \bar{h}_2}{G_R \cdot b \cdot l^2}}$$

$$a_1 = \left(\frac{h_1}{2} + \bar{h}_1 + \frac{h_2}{2} \right) - a_2; \quad a_3 = \left(\frac{h_2}{2} + \bar{h}_2 + \frac{h_3}{2} \right) + a_2$$

$$a_2 = \frac{\gamma_1 \cdot A_1 \cdot \left(\frac{h_1}{2} + \bar{h}_1 + \frac{h_2}{2} \right) - \gamma_3 \cdot A_3 \cdot \left(\frac{h_2}{2} + \bar{h}_2 + \frac{h_3}{2} \right)}{\sum_{i=1}^3 (\gamma_i \cdot A_i)}$$

The verification of the bending performance is done by determination of the bending stress at the boundary of the boards. The bending stress in the middle of the boards may remain unconsidered.

$$\sigma_{m,r,i,d} = \pm \frac{M_d}{I_{ef}} \cdot \left(\gamma_i \cdot a_i + \frac{h_i}{2} \right) \leq f_{m,d}$$

The verification of the shear performance is done by determination of the shear stress in the decisive plane:

$$\tau_{v,d} = \frac{V_d \cdot \gamma_i \cdot S_i}{I_{ef} \cdot b} \leq f_{R,d}$$

Legend:

- h_i = thickness of the layer i parallel to the direction of load transfer [mm]
- \bar{h}_i = thickness of the layer i perpendicular to the direction of load transfer [mm]
- b = width of the element [mm]
- n = number of layers
- l = span width [mm]
- I_{ef} = effective moment of inertia [Nmm²]
- G_R = rolling shear modulus [N/mm²]
- E_0 = modulus of elasticity parallel to the grain of the boards [N/mm²]